

# Comò

## Lilli & Soft

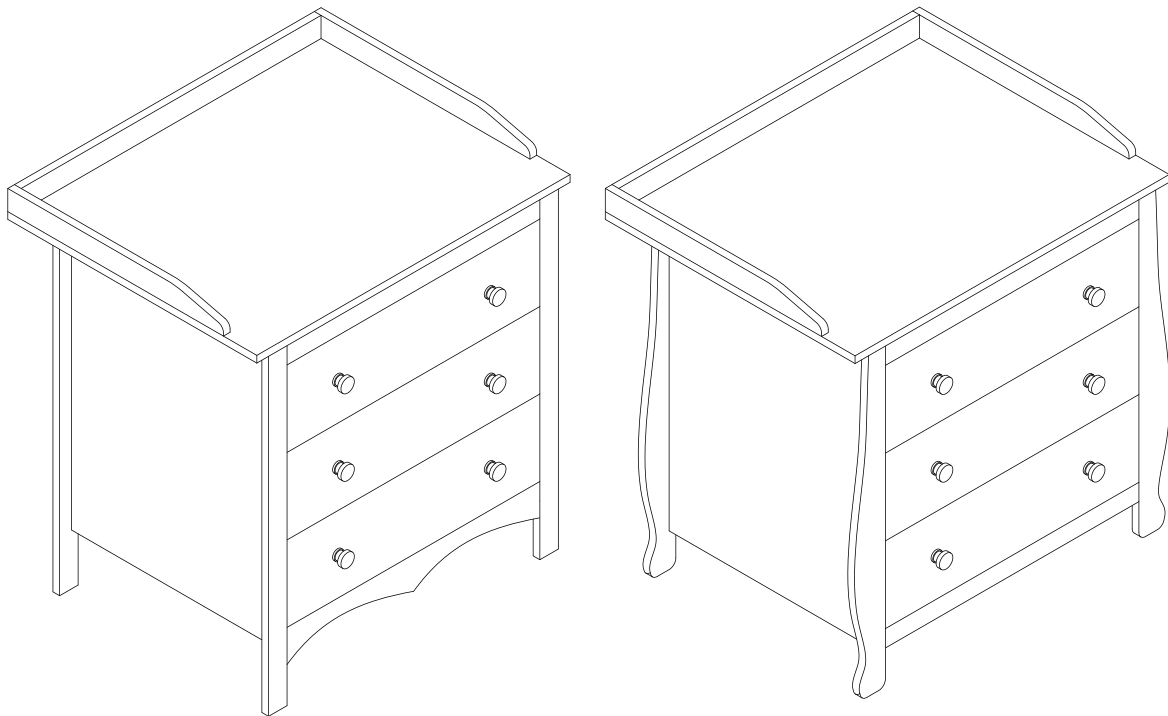

### *Istruzioni di montaggio*

**IMPORTANTE: CONSERVARE PER FUTURI RIFERIMENTI  
LEGGERE ATTENTAMENTE**

SI CONSIGLIA DI CONTROLLARE ACCURATAMENTE TUTTI GLI ELEMENTI PRIMA DEL MONTAGGIO E DI SEGUIRE ATTENTAMENTE LE ISTRUZIONI.  
LA DITTA SI RISERVA DI NON SOSTITUIRE GRATUITAMENTE EVENTUALI ARTICOLI MONTATI NONOSTANTE CERTI ELEMENTI FOSSERO TROVATI  
PRECEDENTEMENTE ROVINATI O IL DANNO FOSSE CAUSATO DA ERRATO MONTAGGIO O ERRATO UTILIZZO DEL PRODOTTO

**IMPORTANT: KEEP FOR FUTURE REFERENCE  
READ CAREFULLY**

WE SUGGEST TO CONTROL CAREFULLY ALL ELEMENTS BEFORE THE ASSEMBLING AND TO FOLLOW CAREFULLY INSTRUCTIONS.  
COMPANY WILL NOT SUBSTITUTE FOR FREE ITEMS ASSEMBLED EVEN IF ELEMENTS WERE FOUND BROKEN,  
OR IF THE DAMAGE IS CAUSED FROM WRONG ASSEMBLING OR WRONG USE OF THE ITEM

# Lista dei componenti

## Componenti struttura

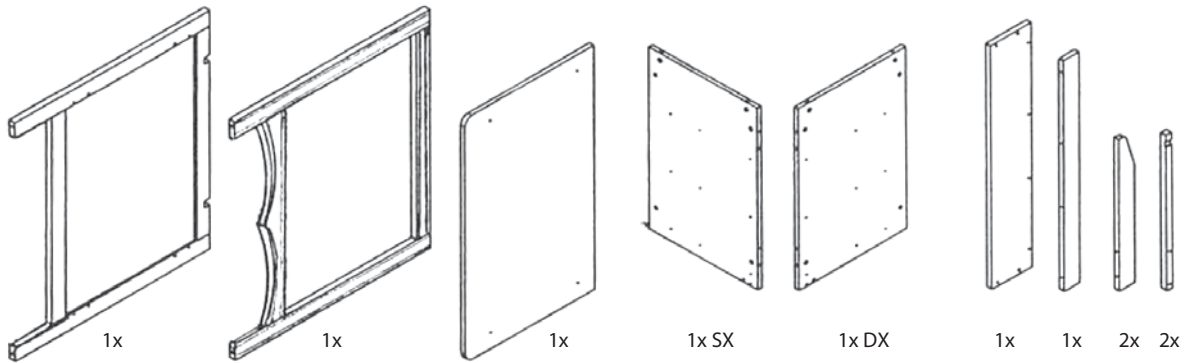

## Componenti cassetti

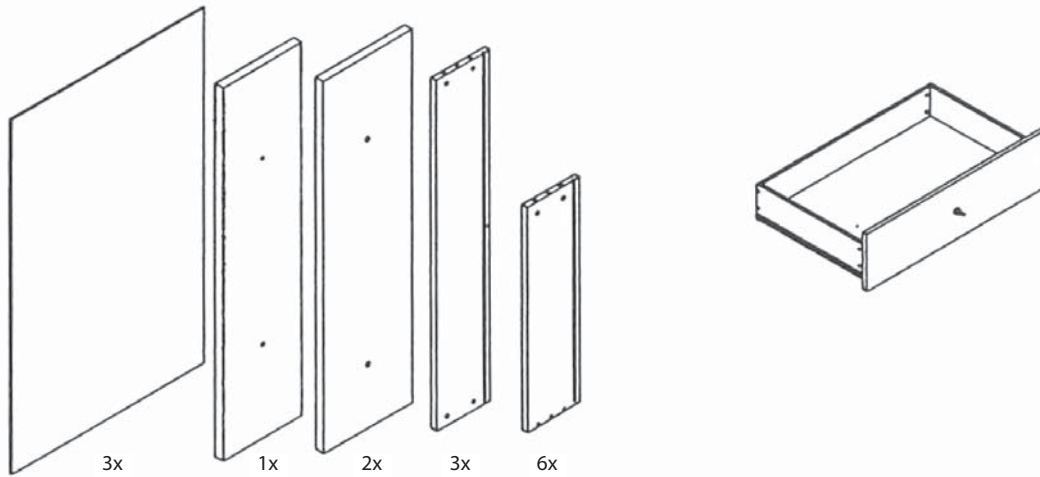

## Ferramenta Hardware

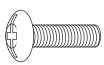

6xA  
25 mm



12xB  
8x30 mm

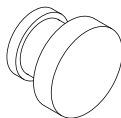

6xC

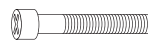

4xD  
50 mm



4xE  
40 mm

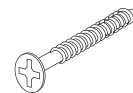

4xF  
45 mm



12xG  
30 mm



1xH



3xI  
20 mm

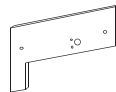

3xJ  
Freno per guida cassetto  
Brake for drawers guide

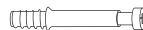

12xK  
44 mm



12xL  
d.15 mm

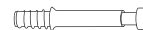

6xM  
42 mm



6xN  
d.12 mm



18xO  
12mm



1xP



3DX+3SX xQ  
Guida per fianco  
Guide for side panel



3DX+3SX xQ1  
Guida per cassetto  
Guide for drawer

### Attrezzi necessari Tools needed

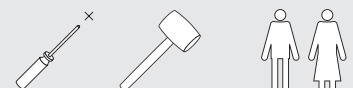

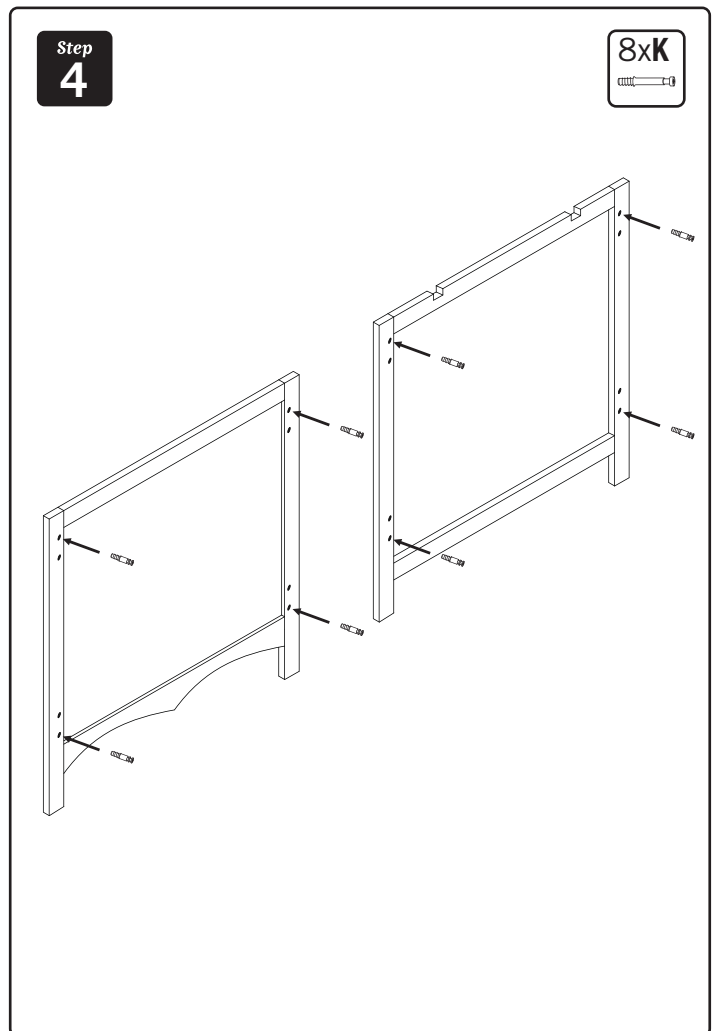
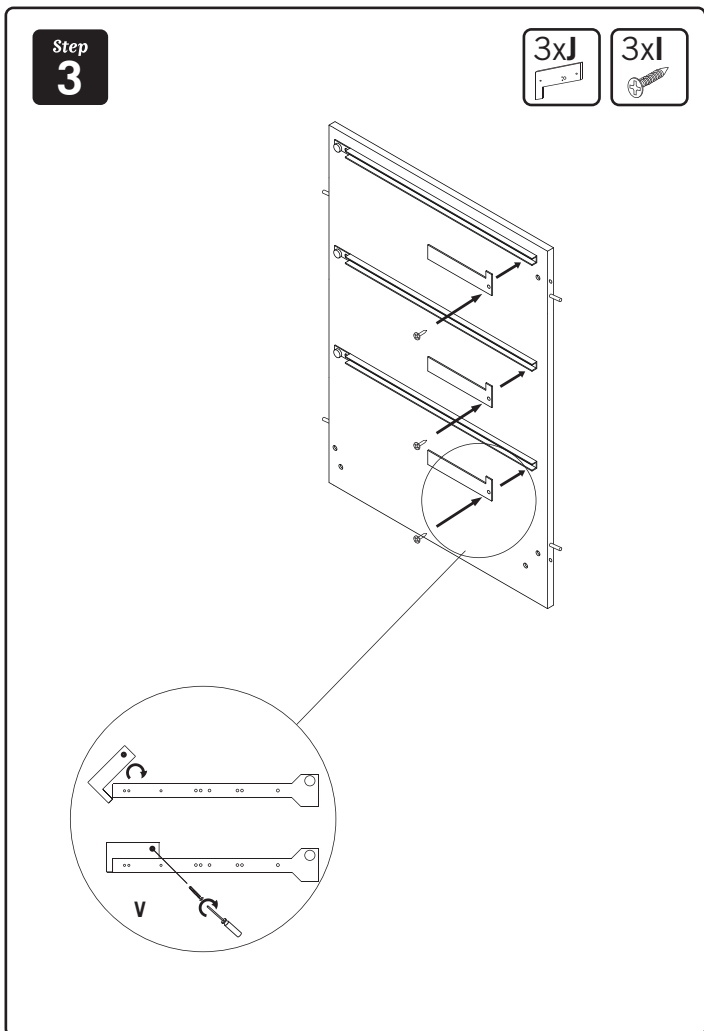
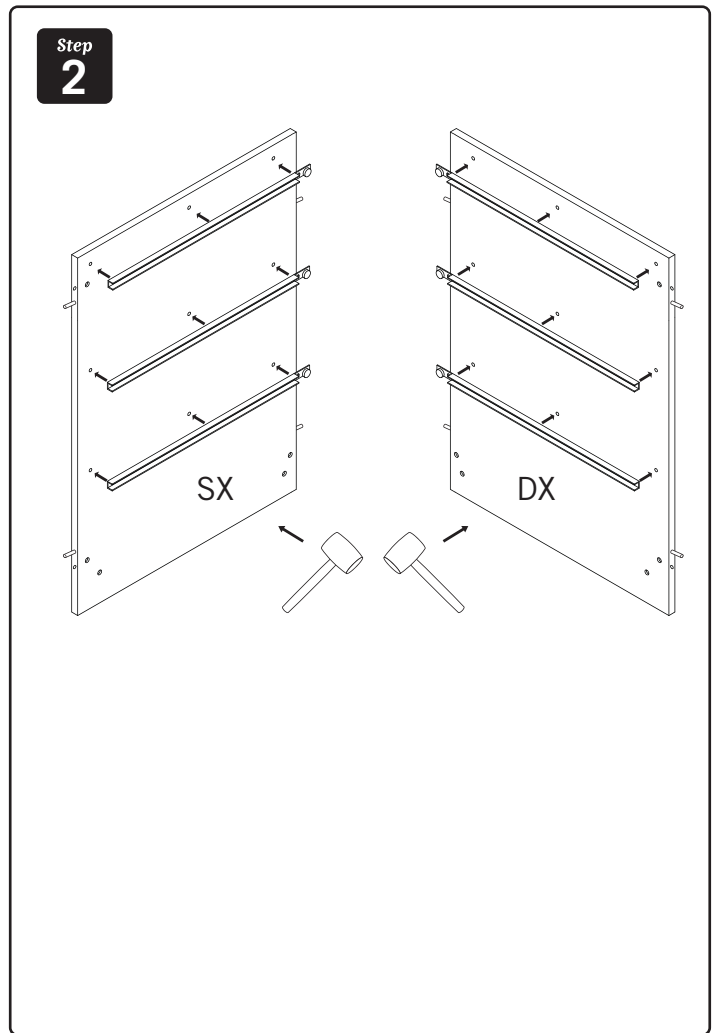
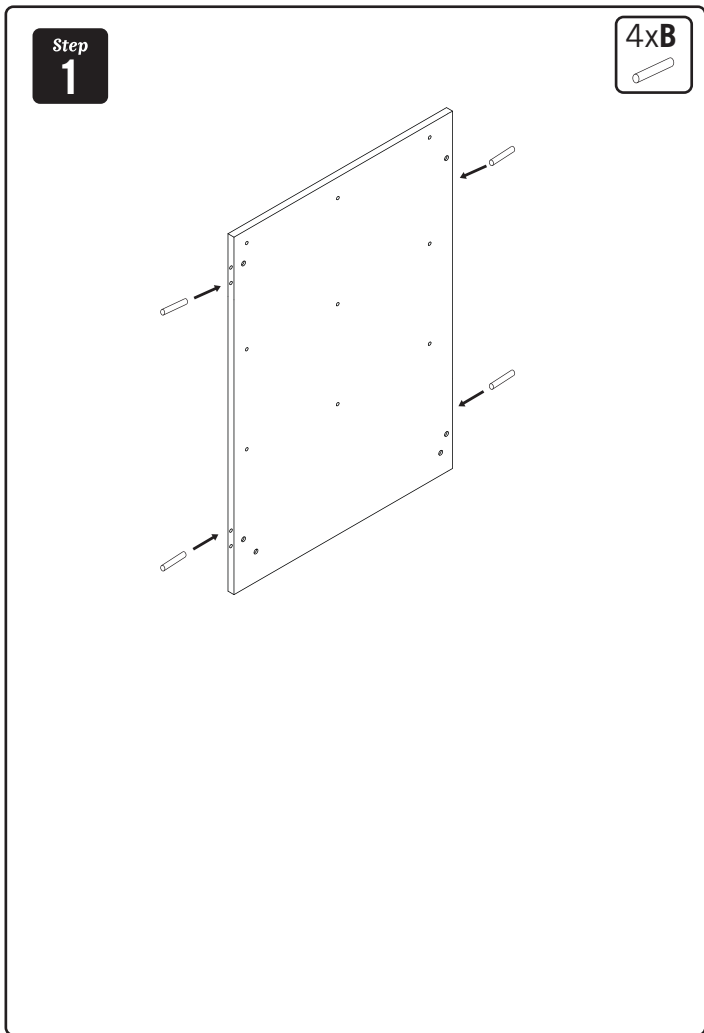

Step  
**5**

4xK  

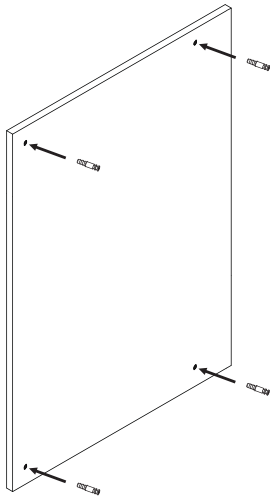

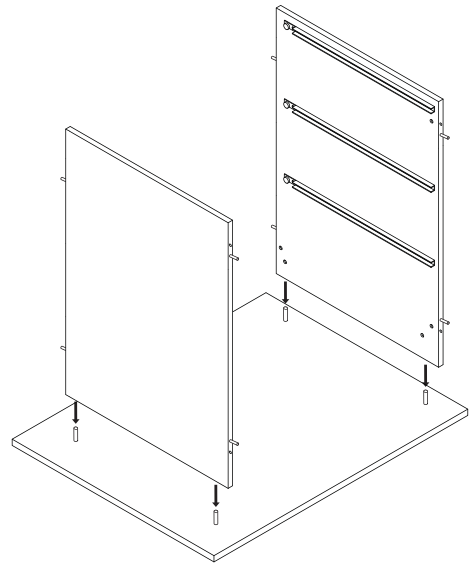

Step  
**6**

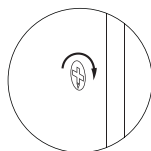
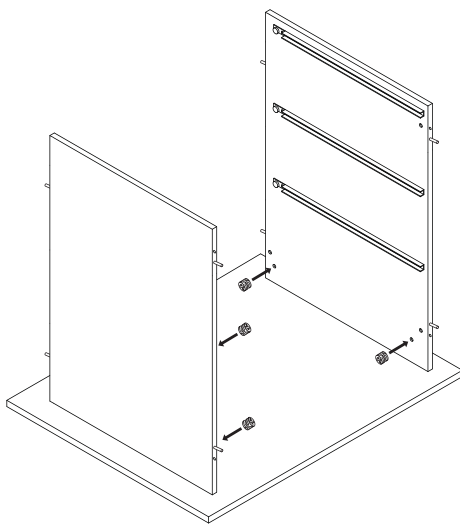

Step  
**7**

4xL  

Step  
**8**

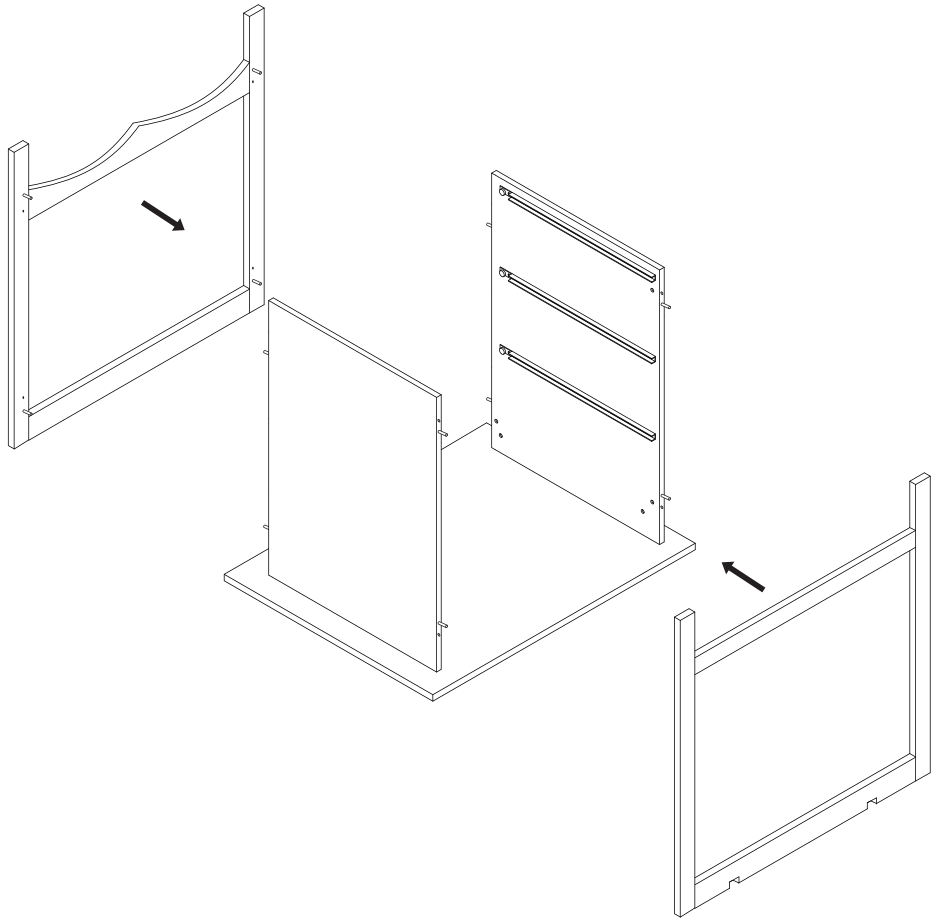

Step  
**9**

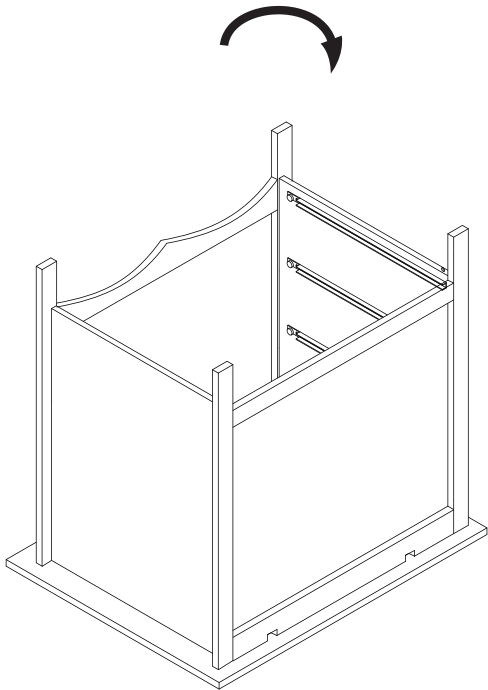

Step  
**10**

8xL

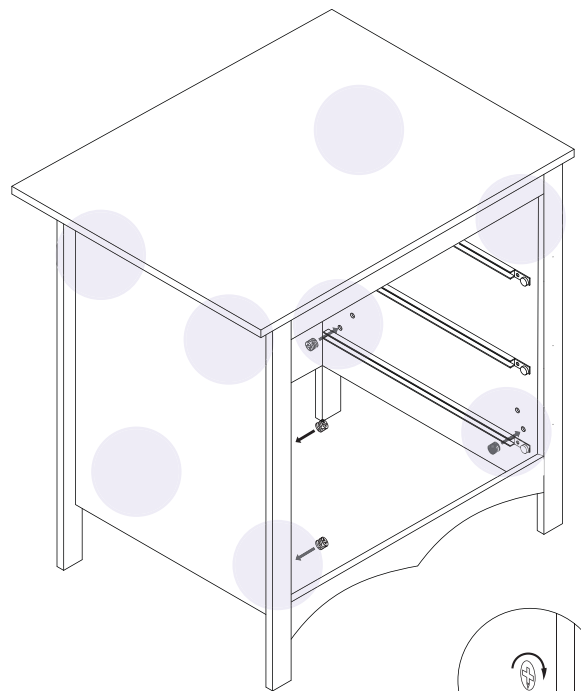

Step  
**11**

2xM

2xN

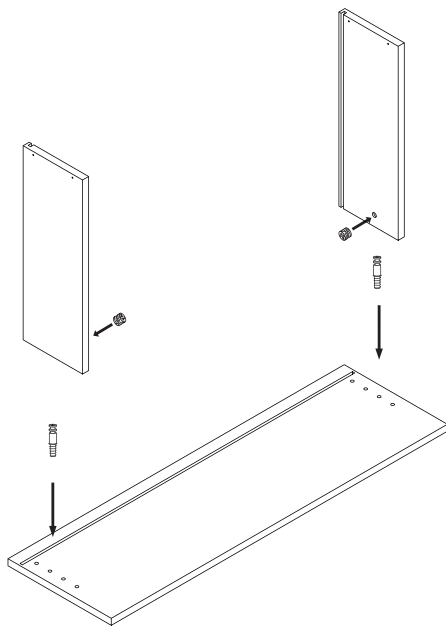

Step  
**12**

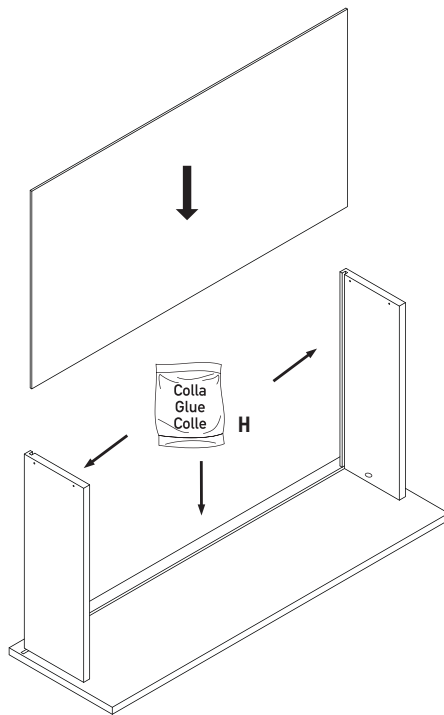

Step  
**13**

4xG

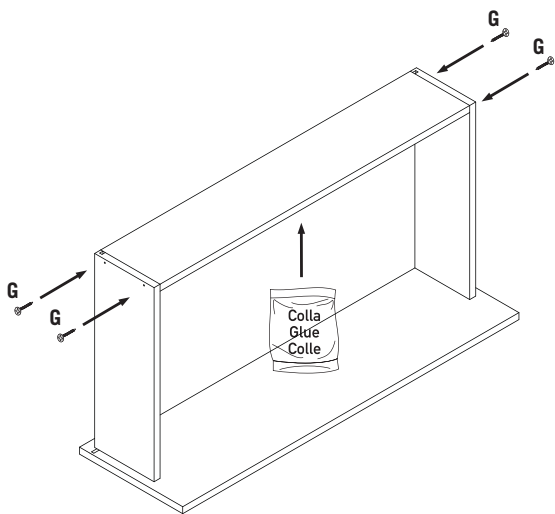

Step  
**14**

6xO

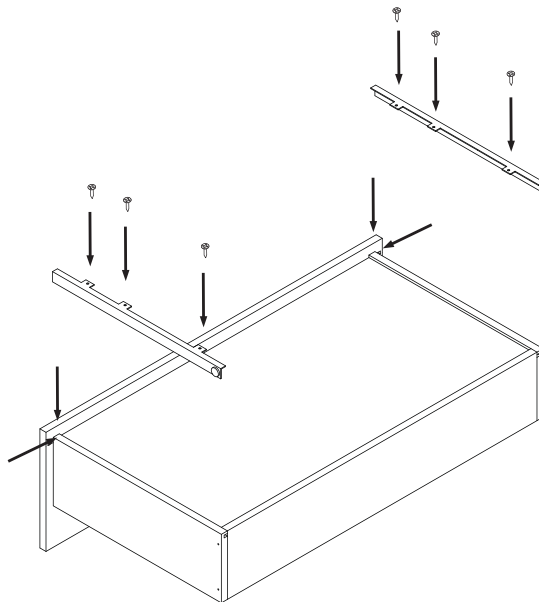

Step  
15

2xA  

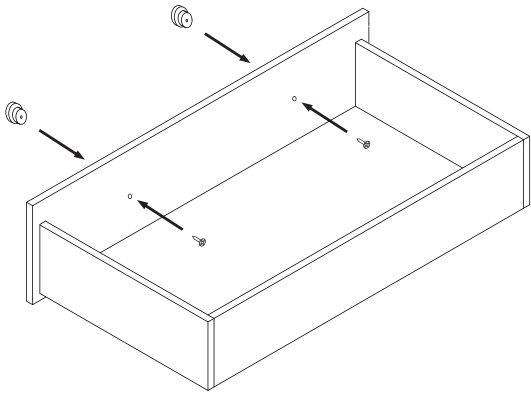
Step  
16

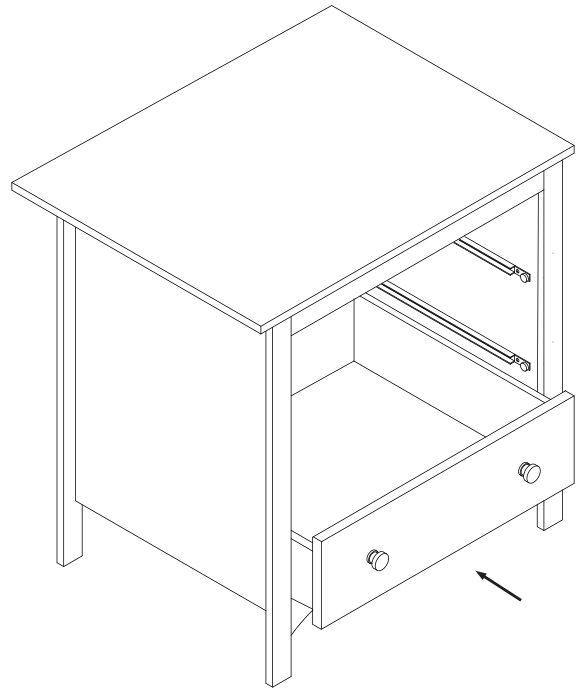

Step  
17

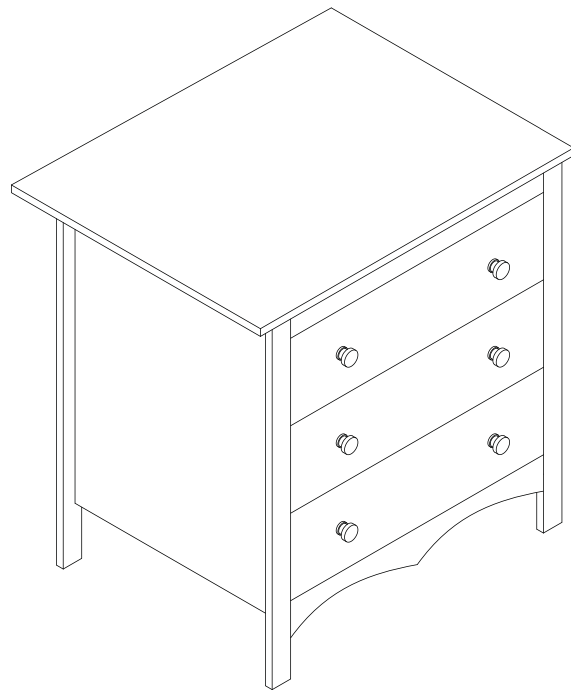

Step  
**18**

2xB  

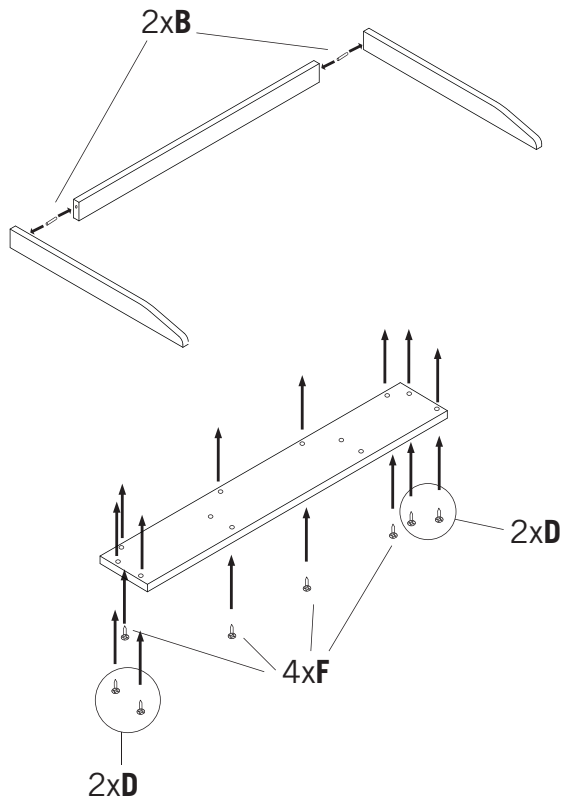

4xD  

4xF  



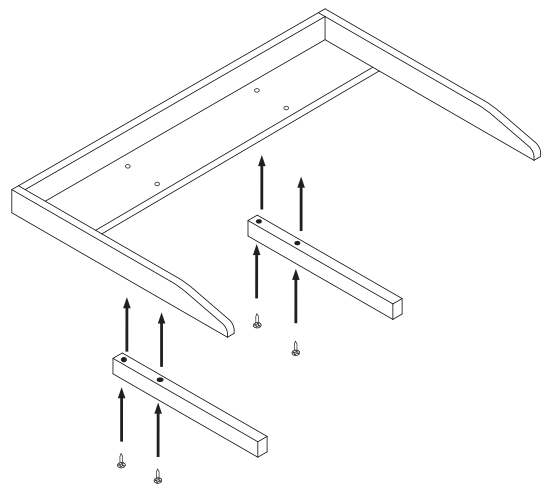

Step  
**19**

4xE  

Step  
**20**

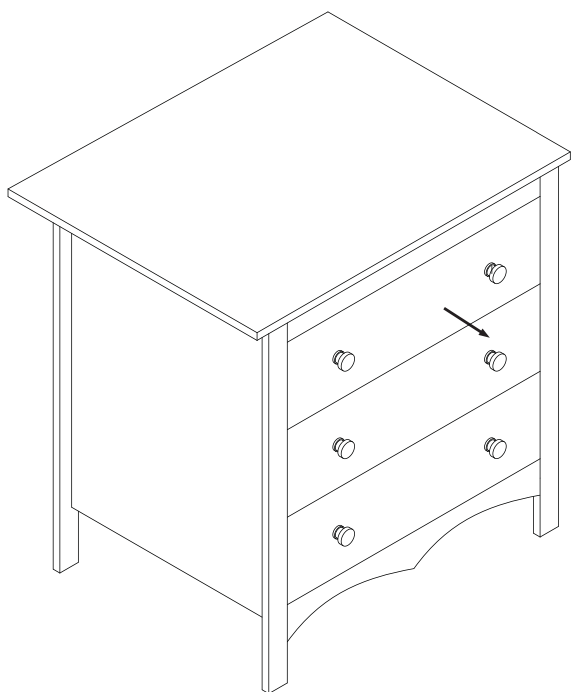

Step  
**21**



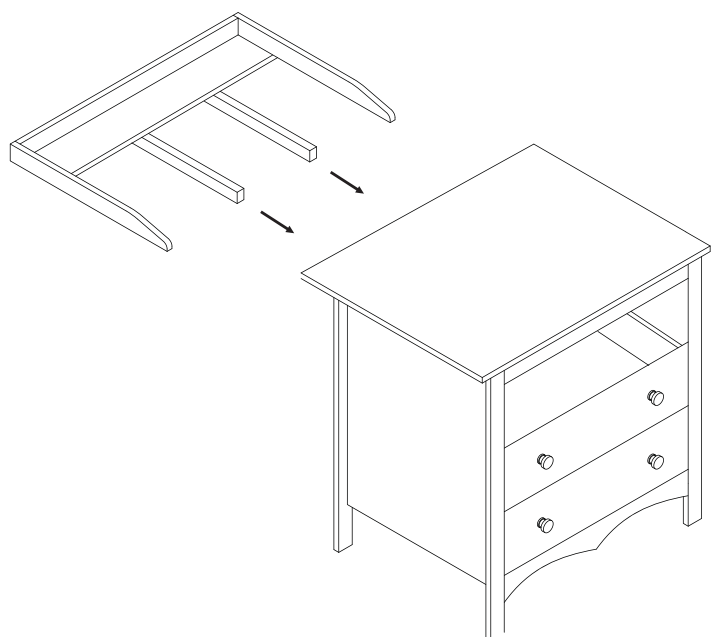

Step  
22

2xB  

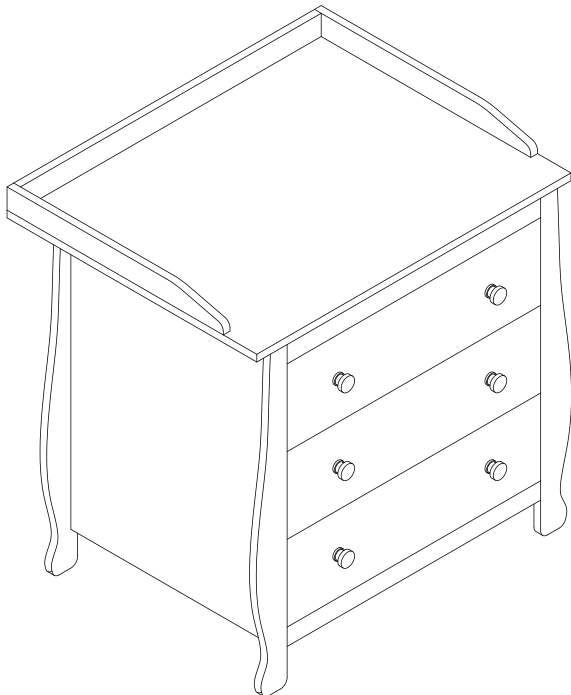
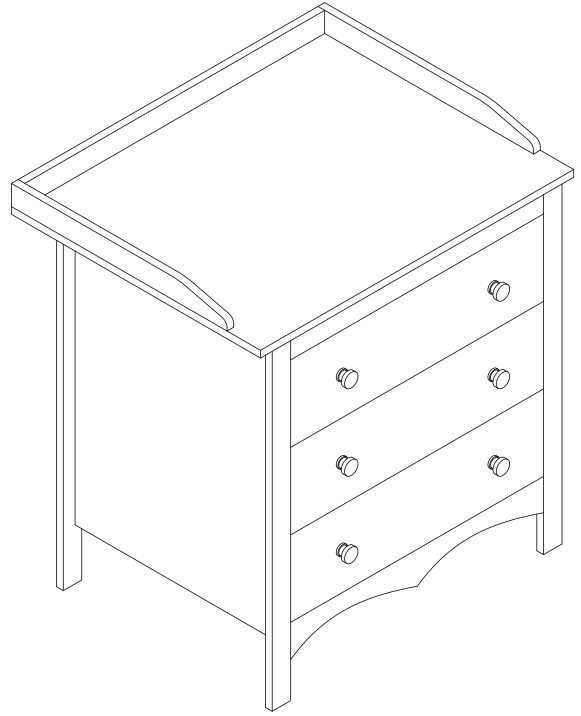
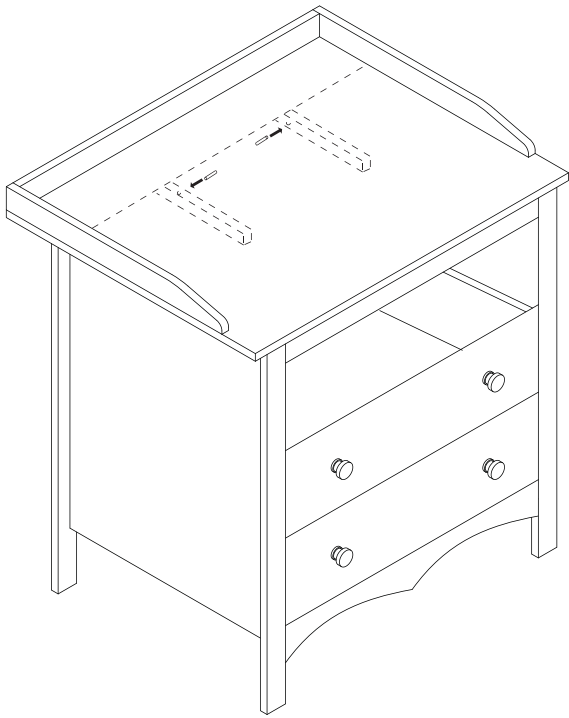
## RIMOZIONE DELLA PROLUNGA FASCIATOIO

1. Estrarre il cassetto superiore.
2. Rimuovere i 2 blocchi (spine in legno B) dalle barre interne della prolunga.
- 3-4. Sfilare le barre interne tirando da dietro la prolunga fasciatoio.

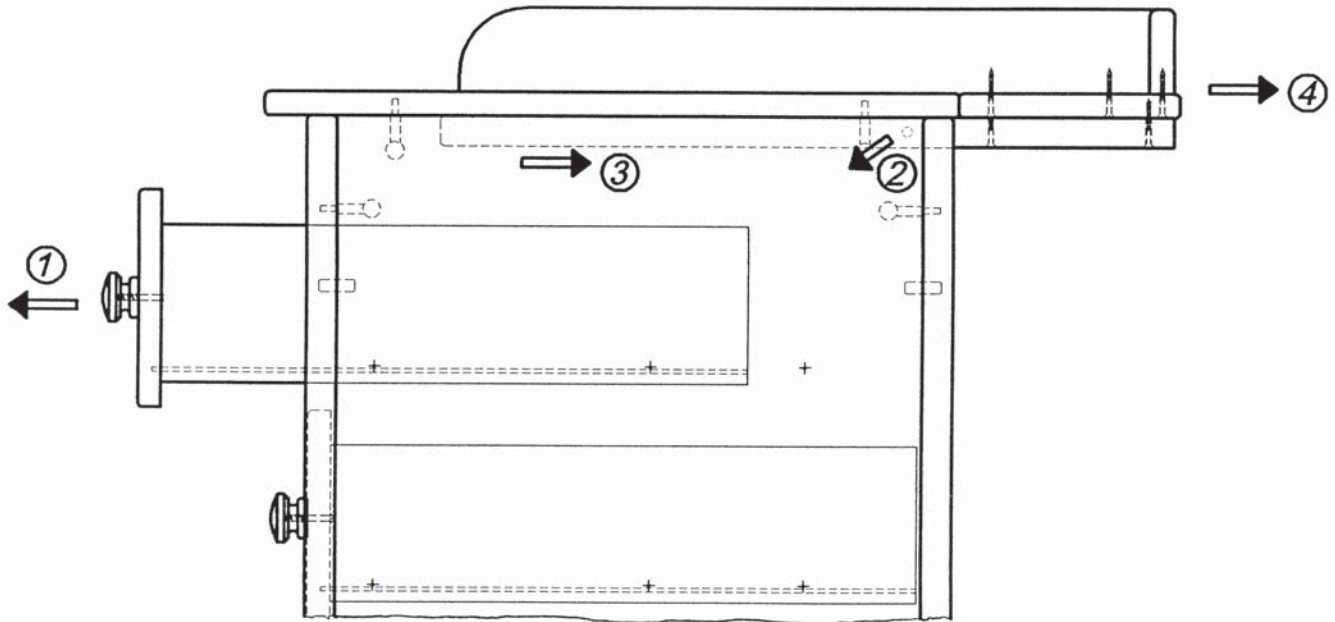

## INFORMAZIONI IMPORTANTI

### Leggere attentamente e conservare per un utilizzo futuro

Il vostro comò/fasciatoio vi garantirà molti anni senza problemi di manutenzione se utilizzato e trattato in modo appropriato, come indicato nelle seguenti istruzioni.

Rimuovete l'imballaggio con attenzione e verificate che siano presenti ed integre tutte le parti elencate nella lista dei componenti.

Evitate di bagnare le parti del mobile. Se esso viene collocato in bagno, se si bagna deve essere subito asciugato con un panno morbido e asciutto. Mantenere una buona aerazione nella stanza.

L'articolo soddisfa i requisiti di sicurezza della norma EN 12221-1:1999 (standard europeo per le norme di sicurezza per i fasciatoio).

Per il montaggio sono necessari: 1 martello, 1 cacciavite a taglio, 1 cacciavite a croce, 1 chiavetta esagonale (fornita). Il montaggio deve essere effettuato da 2 persone adulte.

## SICUREZZA

- Non lasciate mai il bambino incustodito sul fasciatoio.
- Non posate oggetti pesanti sulla prolunga fasciatoio: il mobile potrebbe rovesciarsi all'indietro.
- Assicuratevi periodicamente che tutte le viti di fissaggio siano ben serrate e che non ci siano parti allentate che potrebbero diventare punto di appiglio per il bambino o per i suoi vestiti, catenine, lacci vari.
- Serrate nuovamente tutte le viti in periodi regolari.
- Assicuratevi che il mobile non sia danneggiato in alcun modo.

## ATTENZIONE

Evitate di collocare il fasciatoio in prossimità di fiamme libere o altre fonti di calore (es. stufe elettriche, fornelli a gas, ecc.).

## PULIZIA

Il mobile può essere pulito con un panno morbido. Utilizzate un prodotto non aggressivo se necessario. Quando il mobile viene pulito, deve essere subito asciugato.

# Smaltimento materiale di imballo

Gentile Cliente,

le forniamo qui di seguito brevemente le linee guida per il corretto smaltimento del materiale di imballo.

1) SCATOLONE DI CARTONE ,FOGLI SI CARTONE INTERNI

Seguire le disposizioni del suo comune per la raccolta differenziata di carta e cartone.

2) SACCHETTI DI NAYLON (O NAYLON BOLLICINATO O POLISTIROLO)

Seguire le disposizioni del suo comune per la raccolta differenziata della plastica.

Le ricordiamo inoltre che, una volta dismesso, il suo lettino o bagnetto fasciatoio, o armadio o culla, non vanno dispersi nell'ambiente, ma correttamente conferiti ai centri di raccolta presenti nel proprio comune di residenza.

Un comportamento consapevole per il rispetto della natura.

Grazie.

Disposal of packaging material

Dear Customer,

we briefly provide you with the following guidelines for the proper disposal of packaging material.

1) CARDBOARD BOX ,INTERNAL CARDBOARD SHEETS.

Follow the regulations of your municipality for separate collection of paper and cardboard.

2) NYLON (OR BUBBLED NYLON OR STYROFOAM) BAGS.

Follow your municipality's regulations for separate collection of plastic.

We also remind you that, once disposed of, your crib or changing table, or closet or crib, should not be dispersed in the environment, but properly delivered to the collection centers present in your municipality of residence.

Conscious behavior for the respect of nature.

Thank you.

Élimination des matériaux d'emballage

Cher client,

voici quelques conseils pour l'élimination correcte des matériaux d'emballage.

1) BOÎTE EN CARTON, FEUILLES DE CARTON INTÉRIEURES

Respectez les règles de votre municipalité en matière de collecte sélective du papier et du carton.

2) SACS EN NYLON (OU PAPIER BULLE EN NYLON OU EN POLYSTYRÈNE)

Respectez les règles de votre commune en matière de collecte sélective du plastique.

Nous vous rappelons également qu'une fois mis au rebut, le lit ou le matelas à langer, l'armoire ou le berceau ne doivent pas être dispersés dans l'environnement, mais doivent être correctement recyclés.

dans l'environnement, mais doivent être déposés correctement dans les points de collecte de votre commune.

Un comportement conscient pour le respect de la nature.

Nous vous remercions.